

EVA 3.0 Tensionnerless back Instructions:

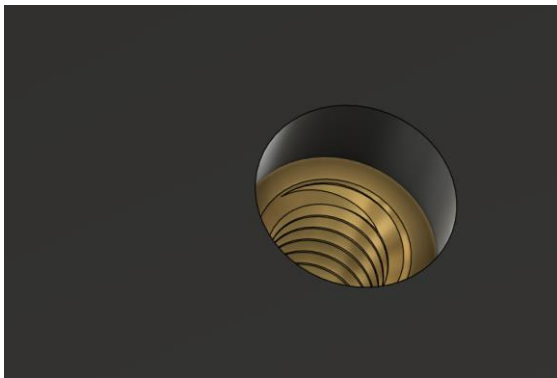

- Insert all heatinserts in the 4 holes, be sure to insert it further 2mm past the surface

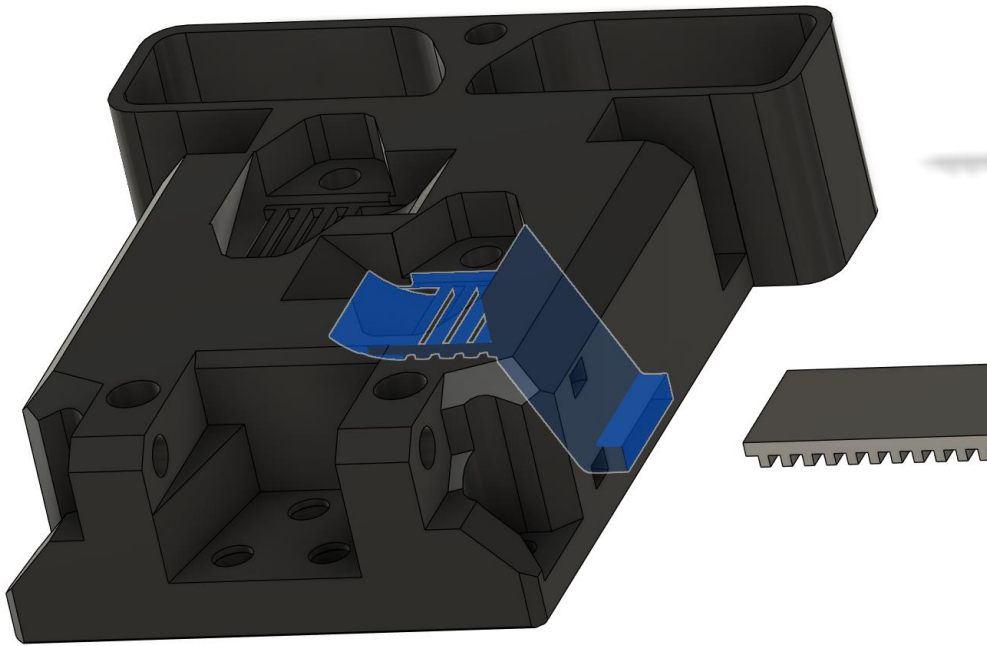

- Insert the belt in the orifice, push it to make the turn

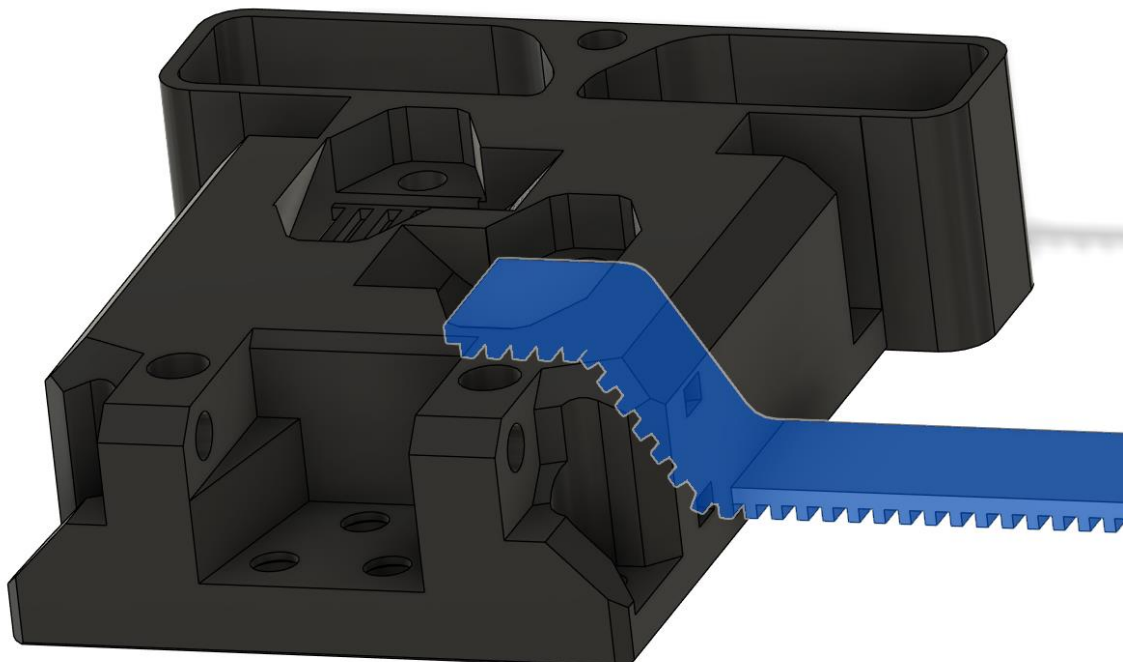

- This should be the result

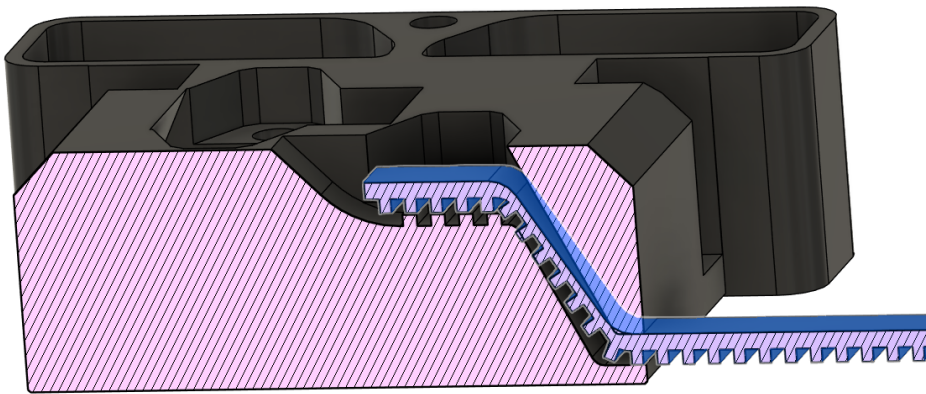

- This is the cutted view of the assembly

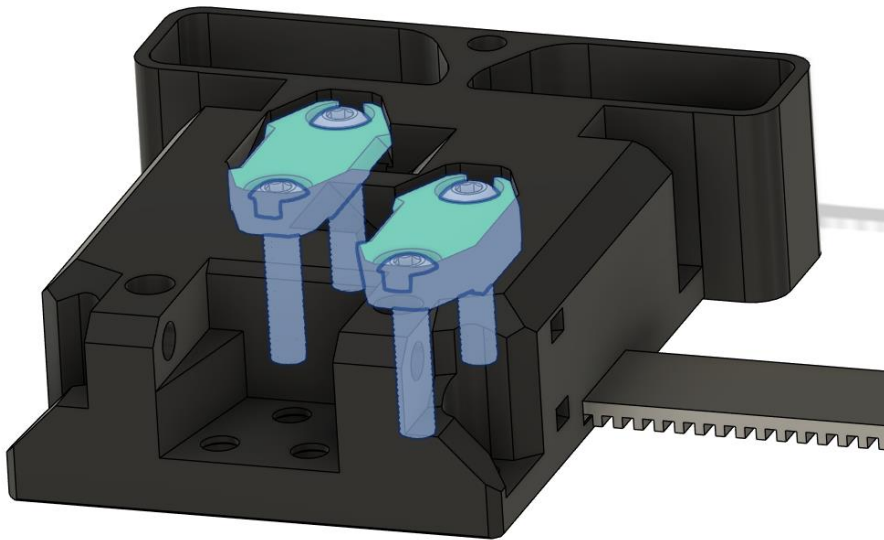

You can now secure the belts with the grabber with 2 M3x14 rounded head screws

After this you can install you Fan options to the toolhead